

ISO 9001:2008

Columbus JACK/Regent

"The Strength of Experience"

PRODUCT DATA SHEET

ALLIGATOR AXLE JACK

Model 53D22034, 20 Ton Capacity

NSN: 1730-00-540-1238

CAGE CODE: 00994

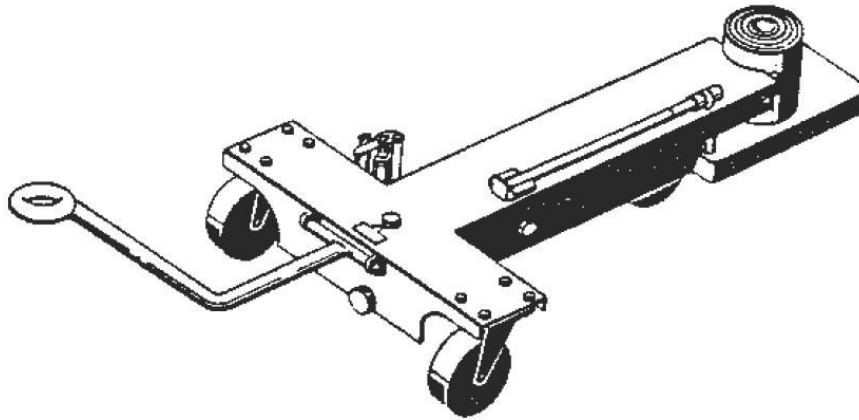

ALLIGATOR AXLE JACK SPECIFICATIONS

VERTICAL CAPACITY (Lbs/kg)	MINIMUM (CLOSED) HEIGHT (Inches/mm)	HYDRAULIC LIFT (Inches/mm)	SCREW EXTENSION (Inches/mm)	MAXIMUM HEIGHT (Inches/mm)	JACK NET WEIGHT (Est.) (Lbs/kg)	JACK OVERALL DIMENSIONS L x W x H (Inches/mm)	CRATED WEIGHT (Est.) (Lbs/kg)	CRATE DIMENSIONS (Est.) L x W x H (Inches/mm)
40,000	9.0	15.0	5.0	29.0	230	67 x 36 x 12	300	69 x 38 x 20
14,930	229	381	127	737	86	1,702 x 914 x 305	112	1,753 x 965 x 508

Rev 08/09